

SAFES AND CABINETS

PRODUCT CATALOGUE 2026



ChubbsafesTM
Trusted the world over.



T2

SECURITY UPGRADE

Shown here is the TriForce T2 which has undergone explosion testing (EX).

BURGLARY RESISTANCE SECURITY UPGRADE

The EN standard used in certifying safes and cabinets with a high level of burglary resistance has been recently updated to accommodate advanced tooling. These new tools are now listed in the standard under the “T2” tool list.

This means more sophisticated and powerful tools like a new generation of circular saws and thermal lances are used in independent burglary tests to prove our products’ ability to resist them. This upgrade guarantees the highest current performance in physical security.

Chubb safes is one of the first brands in the physical security industry to launch T2-certified safes. Learn more about the T2 security upgrade on our website www.chubbsafes.com.

CONTENTS

FINDING YOUR SAFE	7
TEST STANDARDS	8
PRODUCT OVERVIEW	10
LOCKING OPTIONS	11
PRODUCTS	
OPTIONAL FITTINGS	45

Consul	11
Senator	12
DuoGuard GI T2	13
DuoGuard GII T2	14
DuoGuard GIII	15
ProGuard GIII	16
Europa GI-III T2	17
Vega	18
Europa GVI	19
Europa GV T2	20
DuoForce T2	21
TriForce T2	22
Sigma Deposit	23
Omega Deposit	24
Rhino Mk II DT	25
Europa Deposit	26
ProGuard DT	27
Executive	28
DPC	29
6000 Series Files	30
Fire File 25"	31
Fire File 31"	32
Lateral Fire File	33
Binder Fire File	34
Ultra Fire file 31"	35
DataGuard NT	36
Air Hotel	37
Air	38
Fortis	39
HomeSafe S2 30P	40
Rhino Mk II	41
Mini Banker Mk II	42
Archive Cabinet	43
ForceGuard	44

ICONS EXPLAINED



Burglary



Fire
paper doc.



Fire
data media



Explosives

CERTIFIED BY DEKRA

ISO-CERTIFIED PRODUCTION SITES

We list sustainability very highly on our agenda; setting high standards for our products, our employee working conditions and for the environment in which we live.

The Chubb safes products that are manufactured in our production sites are created under the most stringent production processes following the principles of the latest quality, health and safety and environmental management systems, and demonstrate our clear commitment to sustainability.



All Gunnebo Safe Storage production sites are certified according to ISO 14001 Environmental Management System, ISO 9001 Quality Management System and ISO 45001/OHSAS 18001 Occupational Health & Safety System.



Trusted the world over, Chubb safes is the oldest brand for safes, vaults and vault doors in the world. Chubb safes solutions are well known and appreciated for their unique combination of robustness, reliability and modern designs.

Having provided high-quality protection solutions for almost two centuries, Chubb safes combines experience with innovation to create trustworthy products for maximum protection against burglary, fire and explosives.

The Chubb safes solutions are rigorously tested by international and independent accreditation bodies to guarantee the best protection available.

The Chubb safes brand is used by Gunnebo under license.

Chubb safes
Trusted the world over.

WHICH **SAFE** IS RIGHT FOR YOU?

The most important initial question is what you want to protect – cash and valuables, documents or data media?

CASH AND VALUABLES

Choose from the burglary protection range. This includes safes, cabinets, vaults & vault doors, designed to withstand physical attacks in different strengths or Grades. Each Grade represents a particular “cash rating” which is the amount an insurer will cover.

The actual amount of cover can vary between insurance companies and country, and may be different to the manufacturer's recommended rating. You should always check what cover your insurance company is prepared to offer.

DOCUMENTS AND DATA MEDIA

Choose from the fire protection range which includes safes and filing cabinets designed to keep documents or data media safe from the effects of a fire.

DOCUMENTS

To survive a fire, documents require protection from temperatures higher than 170°C. Therefore cabinets have to be specifically designed, tested and then certified for this task. Without a credible certification, you cannot be sure that your documents are safe.

DATA MEDIA

The same is valid for data media, except here the cabinet must offer much greater protection due to the sensitivity of the material. If the inside of the cabinet exceeds a mere 50°C, then the information on a CD, DVD or tape will be destroyed.



CERTIFIED STRENGTH

To provide the appropriate level of protection, the products are tested to comply with the latest industry standards. The various certification tests carried out in independent laboratories for burglary or fire protection are conducted by experienced operators armed with plans of the product and a whole range of tools.

FOR BURGLARY PROTECTION, safes and vaults are awarded grades:

- For security cabinets, there are Grades S1 and S2 (EN 14450).
- For safes, vaults and vault doors, they are rated from Grade 0 to Grade XIII (EN 1143-1).
- High security locks are graded according to EN 1300 in security levels A, B, C and D, the highest.

During the certification process, door panels of the products, bolt works, locks and handles are tested. The certification tests include an attack program that is devised so that various break-in attempts can be made using a selection of tools. A correlation between tool type and the time for which each one is used can be used to obtain a resistance score (resistance unit). The higher the score, the higher the level of resistance. Based on the results obtained, the safe is given a classification and then listed in a resistance grade.

FOR FIRE PROTECTION, these standards vary according to whether you want to protect paper documents, digital media or other highly sensitive objects. This is because the temperature at which data media (e.g. 50°C) and documents (e.g. 170°C) deteriorate differs according to the item protected:

- In order to fully protect data media, industry standards indicate that products should carry ECB•S EN 1047-1, UL 72 Class 125 or NT Fire 017 60/120 DIS.

The ECB•S and UL tests monitor the internal temperature of the data cabinet until it has completely cooled down during the “soakout” period. Assessing products during this period is essential, since internal temperatures can peak up to six to eight hours after a fire has been extinguished. Such tests ensure that all products are comprehensively tested and, upon passing, will fully protect your data media for the specific time period stated.

- For document protection, all products must have an appropriate industry standard 30-, 60- or 120-minute paper certificate.

UL 72 Class 350, ECB•S EN 1047-1, EN 15659 or NT Fire 017 are acceptable standards for paper document protection.

LEVELS OF RESISTANCE

Alongside extremely strict standards, you will also find a number of others that are less stringent in terms of resistance.

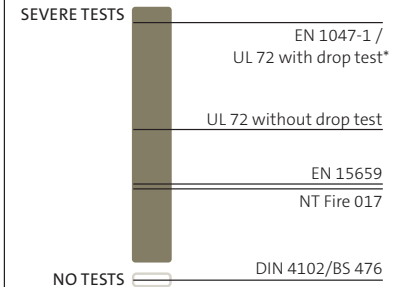

* Test UL 72 does not necessarily involve conducting a drop test.

HIGHEST ALLOWED INSIDE TEMPERATURE

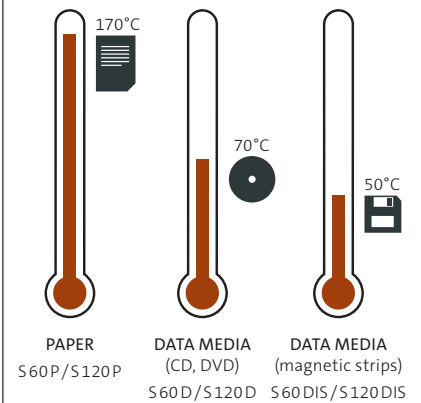

STANDARD IN BRIEF

STANDARDS	TEMPERATURE TEST	DROP TEST	PAPER	DATA MEDIA	COOLING
EN 1047-1	1090°C	9.15 metres	S 60 P (60 min.) / S 120 P (120 min.)	S 60 DIS (60 min.) / S 120 DIS (120 min.)	incl. the cooling period
UL 72	1090°C	9.15 metres (In UL the drop test is optional so always check what is being claimed)	Class 350 (½, 1, 2 hours)	Class 125 (½, 1, 2 hours)	incl. the cooling period
EN 15659	850°C	no	LFS 30 P (30 min.) / LFS 60 P (60 min.)	no application	not tested
NT Fire 017	1090°C	no	60 paper (60 min.) / 90 paper (90 min.) / 120 paper (120 min.)	60 diskettes (60 min.) / 120 diskette (120 min.)	not tested
DIN 4102/BS 476	not tested	not tested	not tested	not tested	not tested

EUROPEAN CERTIFICATION FOR SAFES EXPLAINED

In order to attest to the quality of a certified product, an information plate is adhered to the inside of the product. This provides you with guarantees that the product has been tested and manufactured in an environment that has been checked by the certifying body. Below is shown the ECB•S label and the details listed on the information plate.

BURGLARY PROTECTION CERTIFICATION

EN 1143-1/EN 14450
The European standard that the product meets

CERT. MARK. NO.
Certificate number issued by the certifying body

SERIAL NO.
Each product can be identified by a unique serial number

RESISTANCE GRADE
Resistance classes

WEIGHT
The safe's net weight. Weight may vary by configuration

YEAR OF MANUFACTURE
The year that the product was manufactured

SAFE	
Certified according to EN 1143-1 European Certification Body GmbH, Frankfurt/Main accredited according to ISO/IEC 17065	
Cert. mark No.	
Resistance grade	III
Serial No.	
Weight	
Year of manufacture	

FIRE PROTECTION CERTIFICATION

EN 1047-1/EN 15659
The European standard that the product meets

CERT. MARK. NO.
Certificate number issued by the certifying body

SERIAL NO.
Each product can be identified by a unique serial number

PROTECTION CLASS
Resistance classes

WEIGHT
The safe's net weight. Weight may vary by configuration

YEAR OF MANUFACTURE
The year that the product was manufactured

DATA CABINET	
Certified according to EN 1047-1 European Certification Body GmbH, Frankfurt/Main accredited according to ISO/IEC 17065	
Cert. mark No.	
Protection class	S 120 DIS
Serial No.	
Weight	
Year of manufacture	

Fire testing is undertaken by independent laboratories with certificates issued by certification authorities. Here are some examples of test institutes and certificates that you may encounter: ECB•S, UL, iBMB, MPA Dresden, Applus RTD, RISE, VdS.

FOR MORE DETAILED INFORMATION, contact your insurance company or visit the chubbsafes.com website.

SAFES BY CERTIFICATION

N.B.: **RISE** (Research Institutes of Sweden) is formerly known as **SP** (Technical Research Institute of Sweden).
*CD = Core Drill Protection.

PRODUCT	STANDARD	CLASSIFICATION	CERTIFICATION BODY
BURGLARY PROTECTION			
Air	n/a	n/a	n/a
Air Hotel	n/a	n/a	n/a
Consul	EN 1143-1	Grade 0 to I	ECB*S
Europa GV T2	EN 1143-1	Grade V T2	ECB*S
Europa GVI	EN 1143-1	Grade VI	ECB*S
Europa Deposit	n/a	n/a	n/a
ForceGuard	n/a	n/a	n/a
Fortis	EN 14450	Level S2	ECB*S
Omega Deposit	n/a	n/a	n/a
ProGuard GIII	EN 1143-1	Grade III	ECB*S
ProGuard DT	EN 1143-2	Grade DI to DII	ECB*S
Rhino Mk II DT	n/a	n/a	n/a
Sigma Deposit	n/a	n/a	n/a
Vega	EN 1143-1	Grade V	ECB*S
FIRE PROTECTION			
6000 Series Files	EN 15659	LFS 60 P	ECB*S
Archive Cabinet	n/a	n/a	n/a
Binder Fire File	UL 72 Class 350	2h Fire Resistance	UL
DataGuard NT	NT Fire 017	120 Diskette	RISE
DPC	UL 72 Class 350	2h Fire Resistance	UL
Executive	NT Fire 017 & UL 72 Class 350	60 Paper & 1h Fire Resistance	RISE & UL
Fire File 25"	UL 72 Class 350	1h Fire Resistance	UL
Fire File 31"	UL 72 Class 350	1h to 2h Fire Resistance	UL
Lateral Fire File	UL 72 Class 350	1h Fire Resistance	UL
Ultra Fire File 31"	UL 72 Class 350	1h to 2h Fire and Impact Resistance	UL
COMBINED BURGLARY & FIRE PROTECTION			
DuoForce T2	EN 1143-1 & NT Fire 017	Grade IV T2 to VI T2 (optional CD*) & 60 Paper	ECB*S
DuoGuard GI T2	EN 1143-1 & EN 1047-1 & NT Fire 017	Grade I T2 & S 60 P (M-115 and larger) & 60 Paper	ECB*S & RISE
DuoGuard GII T2	EN 1143-1 & NT Fire 017	Grade II T2 & 60 Paper	ECB*S & RISE
DuoGuard GIII	EN 1143-1 & NT Fire 017	Grade III & 60 Paper	ECB*S
Europa GI-III T2	EN 1143-1 & NT Fire 017	Grade I T2 to III T2 & 60 Paper	ECB*S & RISE
HomeSafe S2 30P	EN 14450 & EN 15659	Level S2 & LFS 30 P	ECB*S
Mini Banker Mk II	EN 14450 & JIS S 1037	Level S2 & 1h	ECB*S & Bandung Institute of Technology
Rhino Mk II	EN 14450 & EN 15659	Level S2 & LFS 60 P	ECB*S
Rhino Mk II DT	n/a	n/a	n/a
Senator	EN 1143-1 & EN 15659	Grade I & LFS 30 P	ECB*S
COMBINED BURGLARY, FIRE & EXPLOSION PROTECTION			
TriForce T2	EN 1143-1 & NT Fire 017	Grade IV T2 to VI T2 & Grade IV T2 EX to Grade VI T2 EX (optional CD*) & 60 Paper	ECB*S

WHICH LOCK IS RIGHT FOR YOU?

Depending on the range, you can customise your product with a different lock. Thus you can benefit from a comprehensive lock offering that includes the latest industry solutions, which offer a wide range of features. So whether it be the “mechanical combination” lock or an electronic solution, you can be sure to have a lock that will meet your security needs. Below the key terms associated with the range of locks.

DEFINITIONS

KEY LOCK: A manual key-operated lock.

MECHANICAL COMBINATION: A mechanical keyless dial lock with a changeable combination.

ELECTRONIC LOCK: An electronically-operated keypad lock with a changeable combination.

MANAGER MODE: Allows one user to control the functions of other combination holders.

NUMBER OF USERS: The number of users able to program in their own access code.

DURESS FEATURE: An alarm engineer can link the lock into a monitored alarm system. Then, using a given procedure, the lock can be operated, the safe opened and a silent signal given to the monitoring station that this is being done under duress.

TIME DELAY: This feature allows for a pre-set delay between operating the lock and being able to open the safe. The operation may vary between lock types.

TIME LOCK: Time lock allows the user to set periods during which the lock may be operated, e.g. during business hours only. The options available will vary between locks.

AUDIT TRAIL: The lock is able to give a report (it will vary in detail from model to model) of usage and may show times of operation, codes used and operations performed.

DUAL CONTROL: Allows two users to enter their details before any operation can be performed.





MODEL SHOWN: CONSUL M-15

CONSUL

BURGLARY-RESISTANT PROTECTION



KEY FEATURES

- Market leading light weight allows for easier installation.
- Burglary protection in accordance with EN 1143-1, as certified by ECB•S for Grade 0 and I.
- Composite door made from 10mm steel with an overall thickness of 35mm.
- The body is 45 mm overall, comprising the inner and outer steel walls, the space between which is filled with a multi-material burglary resistant barrier.
- 25mm diameter steel bolts secure the door, three operating horizontally and two each vertically upwards and downwards.
- Recessed door & concealed internal hinges which give a smooth finish & prevent areas of attack.
- Model 25 & above has the ability to store A4 Binders.
- Consul comes in two lock options:
 - Double-bitted 8 lever, EN 1300 Class A certified key lock to which two 90mm keys are supplied.
 - A user-programmable, EN 1300 Class B electronic lock capable of accepting two differing user codes and a time-delay function.
- The safe is prepared & anchoring kit is supplied to allow the Consul range to be securely base- or rear-fixed to resist unauthorised removal once installed.

PRODUCT SPECIFICATIONS

Grade 0/Grade I

Model	External Height (mm)	External Width (mm)	External Depth (mm)	Internal Height (mm)	Internal Width (mm)	Internal Depth (mm)	Capacity (litres)	Net Weight (kg)
M-15	280/-	370/-	350/-	190/-	280/-	250/-	13/-	40/-
M-20	-/330	-/450	-/330	-/240	-/360	-/230	-/20	-/50
M-25	330	450	400	240	360	300	26	58/59
M-40	450	450	400	360	360	300	39	71/72
M-50	570	450	400	480	360	300	52	85/86
M-65	690	450	400	600	360	300	65	99/100
M-80	850	450	400	760	360	300	82	115/117

External dimensions exclude handle and hinge projections. In line with certification, weights can vary by +/- 5%.



MODEL SHOWN: SENATOR M-65

SENATOR

BURGLARY & FIRE-RESISTANT PROTECTION

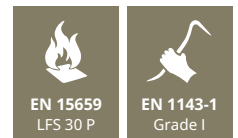

KEY FEATURES

- Dual Certification: Burglary (EN 1143-1) Grade I and Fire (EN 15659, LFS 30 P).
- Certified locks: EN 1300 certified Class A key lock or Class B high-security electronic lock.
- Four models available: 32, 46, 63 or 190 litres.
- Secure bolt work and traditional heavy weight design.
- Enhanced design: removable door for easy installation and a reduced overall weight by 15%.
- Fittings: each safe is supplied with one shelf as standard.
- Attractive appearance: single-colour door and body in dark grey (RAL 7016).
- Ideal for the home or office.

PRODUCT SPECIFICATIONS

Model	External Height (mm)	External Width (mm)	External Depth (mm)	Internal Height (mm)	Internal Width (mm)	Internal Depth (mm)	Capacity (litres)	Net Weight (kg)
M-30	370	500	403	290	420	263	32	121
M-45	500	500	403	420	420	263	46	150
M-65	650	500	403	570	420	263	63	183
M-190	862	654	563	782	574	423	190	329

External dimensions exclude handle and hinge projections. In line with certification, weights can vary by +/- 5%.



MODEL SHOWN: DUOGUARD M-445

DUOGUARD GI T2

BURGLARY & FIRE-RESISTANT PROTECTION



KEY FEATURES

- Burglary protection in accordance to the highest certified resistance levels, available in Grade I T2, certified by ECB•S in accordance with the stringent European standard, EN 1143-1 T2. DuoGuard hereby complies and is certified with the world's strictest requirements for quality and burglary resistance.
- Approved by RISE Research Institutes of Sweden in accordance with fire resistance class NT Fire 017 – 60 paper and RISE's certification rules for fire resisting storage cabinets, SPCR 002.
- Approved by ECB•S in accordance with EN 1047-1, class S 60 P, for one hour of fire protection for paper documents from model M-115 and above.
- Torch-resistant barrier material – Dualite – ensures burglary and fire protection whilst also reducing its total weight and minimising transportation and installation costs.
- Ergonomic soft-touch handle and a range of internal fittings to maximise storage capacity.
- The three-way boltwork is made from solid steel bolts.
- A Class A mechanical key lock or a Class B high-security electronic lock, approved in accordance with EN 1300, are both available as primary lock options.
- Fitted with an active relocker and anti-drilling plates incorporated into the boltwork to withstand burglary attempts.

PRODUCT SPECIFICATIONS

Model	External Height (mm)	External Width* (mm)	External Depth** (mm)	Internal Height (mm)	Internal Width*** (mm)	Internal Depth (mm)	Capacity (litres)	Net Weight (kg)
M-40	435	500	456	335	400	295	40	100
M-60	530	500	521	430	400	360	62	123
M-115	690	600	561	590	500	386	114	175
M-150	875	600	561	775	500	386	150	212
M-205	1150	600	561	1050	500	386	203	264
M-290	1600	600	561	1500	500	386	290	337
M-355	1600	675	585	1500	575	410	354	374
M-445	1850	675	615	1750	575	440	443	436

SPECIFICATIONS FOR **OPTIONAL FITTINGS** ARE AVAILABLE ON PAGE 45

Projection of hinge* (20mm) and projection of handle** (65mm) not included. *** Width excluding shelf racking strips. Racking reduces the internal width by 15mm



MODEL SHOWN: DUOGUARD GII M-115

DUOGUARD GII T2

BURGLARY & FIRE-RESISTANT PROTECTION

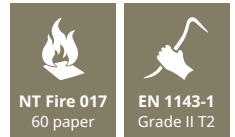

KEY FEATURES

- Burglary protection in accordance to the highest certified resistance levels, available in Grade II T2, certified by ECB+S in accordance with the stringent European standard, EN 1143-1 T2. DuoGuard hereby complies and is certified with the world's strictest requirements for quality and burglary resistance.
- Approved by RISE Research Institutes of Sweden in accordance with fire resistance class NT Fire 017 – 60 paper and RISE's certification rules for fire resisting storage cabinets, SPCR 002.
- Torch-resistant barrier material – Dualite – ensures burglary and fire protection whilst also reducing its total weight and minimising transportation and installation costs.
- The three-way boltwork is made from solid steel bolts.
- Fitted with an active relocker and anti-drilling plates incorporated into the boltwork to withstand burglary attempts.
- A Class A mechanical key lock or a Class B high-security electronic lock, approved in accordance with EN 1300, are both available as primary lock options.
- Ergonomic soft-touch handle and a range of internal fittings to maximise storage capacity.

PRODUCT SPECIFICATIONS

Model	External Height (mm)	External Width* (mm)	External Depth** (mm)	Internal Height (mm)	Internal Width*** (mm)	Internal Depth (mm)	Capacity (litres)	Net Weight (kg)
M-65	578	526	547	452	400	360	65	265
M-115	716	626	587	590	500	386	114	379
M-150	901	626	587	775	500	386	150	456
M-205	1176	626	587	1050	500	386	203	582
M-290	1626	626	587	1500	500	386	290	748
M-355	1626	701	611	1500	575	410	354	829
M-445	1876	701	641	1750	575	440	443	970

SPECIFICATIONS FOR **OPTIONAL FITTINGS** ARE AVAILABLE ON PAGE 45

Projection of hinge*(20mm) and projection of handle** (65mm) not included. ***Width excluding shelf racking strips. Racking reduces the internal width by 15mm



MODEL SHOWN: DUOGUARD M-505

DUOGUARD GIII

BURGLARY & FIRE-RESISTANT PROTECTION

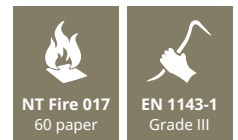

KEY FEATURES

- Burglary protection in accordance with the European standard, EN 1143-1, as certified by ECB•S for Grade III.
- Certified for 1 hour fire resistance by ECB•S in accordance with fire resistance class NT Fire 017 – 60 paper and RISE's certification rules for fire resisting storage cabinets
- Torch-resistant barrier material – Dualite – ensures burglary and fire protection whilst also reducing its total weight and minimising transportation and installation costs.
- The three-way boltwork is constructed from 28mm diameter solid steel bolts.
- Fitted with an active relocker and anti-drilling plates incorporated into the boltwork to withstand burglary attempts.
- A Class B mechanical key lock or a Class B high-security electronic lock, approved in accordance with EN 1300, are both available as primary lock options. The primary lock can be supplemented by a combination lock or both a key lock and electronic lock can be fitted.
- Ergonomic soft-touch handle and a range of internal fittings to maximise storage capacity.

PRODUCT SPECIFICATIONS

Model	External Height (mm)	External Width* (mm)	External Depth** (mm)	Internal Height (mm)	Internal Width*** (mm)	Internal Depth (mm)	Capacity (litres)	Net Weight (kg)	No. of Shelves
M-160	901	626	587	785	510	396	159	415	2
M-215	1176	626	587	1060	510	396	214	517	2
M-305	1626	626	587	1510	510	396	305	687	3
M-370	1626	701	611	1510	585	420	371	753	3
M-465	1876	701	641	1760	585	450	463	880	4
M-505	1876	701	681	1760	585	490	505	915	4

SPECIFICATIONS FOR **OPTIONAL FITTINGS** ARE AVAILABLE ON PAGE 45

Projection of hinge* (20mm) and projection of handle** (65mm) not included. *** Width excluding shelf racking strips. Racking reduces the internal width by 15mm



MODEL SHOWN: PROGUARD M-370



PROGUARD GIII

BURGLARY-RESISTANT PROTECTION

KEY FEATURES

- Burglary protection in accordance with the European EN 1143-1 standard, as certified by ECB+S for Grade III.
- ProGuard's special barrier material provides certified burglary protection whilst also keeping the total weight of the safe down. Less weight means lower transportation costs and greater installation options.
- A higher level of protection can be offered in a safe with reduced wall thickness and increased interior capacity.
- The three-way boltwork is constructed with solid steel bolts.
- For additional security, ProGuard is fitted with an active relocker and anti-drilling plates have been incorporated into the boltwork to withstand burglary attempts.
- Either a mechanical key lock or a high-security electronic lock can be used as the primary lock option. At least one EN 1300 Grade B lock must be fitted as standard.
- Every model can be customised with a range of internal fittings to maximise storage capacity. NOTE: Brackets need to be ordered for each fitting
- ProGuard has a modern design with an ergonomic soft-touch handle.

PRODUCT SPECIFICATIONS

Model	External Height (mm)	External Width (mm)	External Depth (mm)	Internal Height (mm)	Internal Width (mm)	Internal Depth (mm)	Capacity (litres)	Net Weight (kg)
M-65	530	500	521	440	410	359	65	208
M-120	690	600	561	600	510	396	121	320
M-160	875	600	561	785	510	396	159	386
M-215	1150	600	561	1060	510	396	214	481
M-305	1600	600	561	1510	510	396	305	636
M-365	1295	785	620	1205	695	530	363	685
M-370	1600	675	585	1510	585	420	371	701
M-465	1850	675	615	1760	585	450	463	827

SPECIFICATIONS FOR **OPTIONAL FITTINGS** ARE AVAILABLE ON PAGE 45

External dimensions exclude handle and hinge projections. In line with certification, weights can vary by +/- 5%.

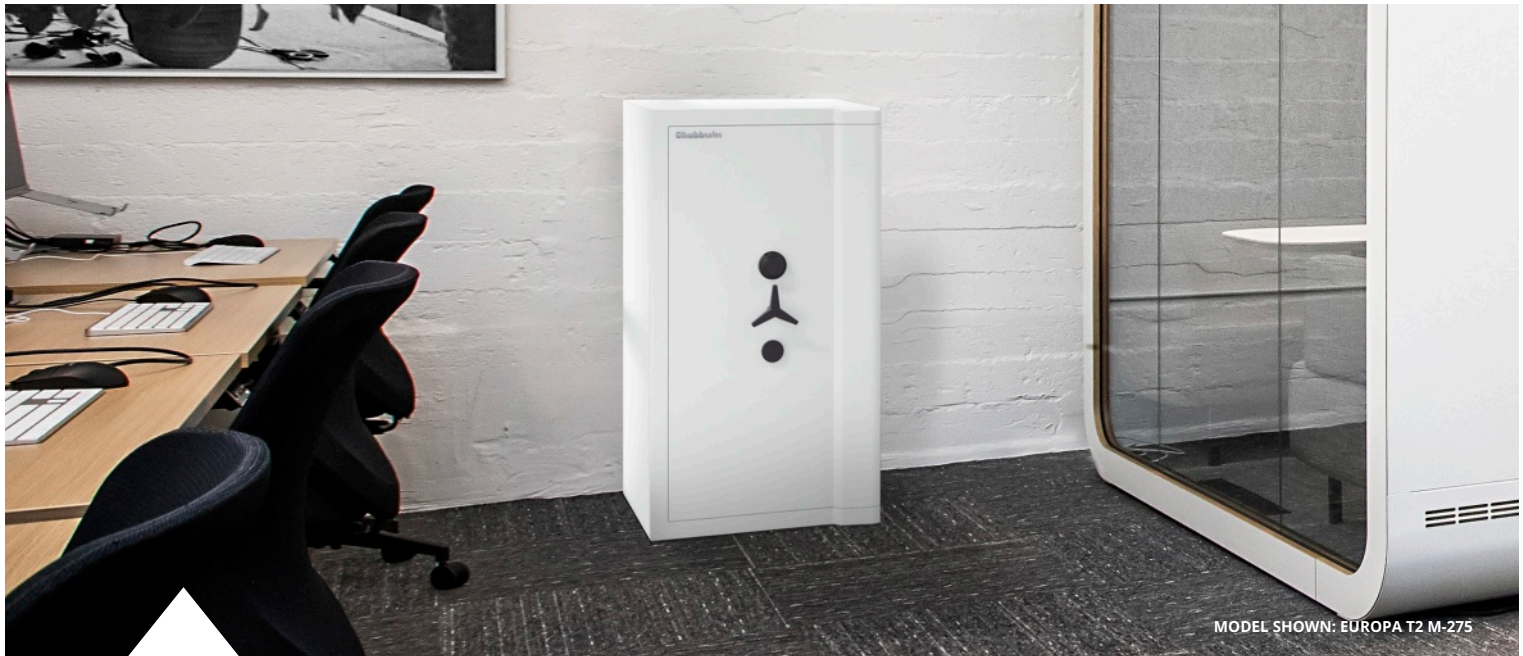

MODEL SHOWN: EUROPA T2 M-275

EUROPA GI-III T2

FIRE & BURGLARY-RESISTANT PROTECTION IN GRADES I T2, II T2, AND III T2

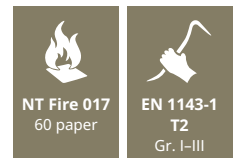

KEY FEATURES

- Professional high security safe protecting valuables up to the highest certified resistance levels, available in Grades I T2, II T2 and III T2, certified by ECB•S in accordance with the stringent European standard, EN 1143-1 T2. Europa hereby complies and is certified with the world's strictest requirements for quality and burglary resistance.
- EN 1143-1:2019 is the latest version of this globally respected burglary resistant standard. The new T2 classification includes tests with the more powerful and effective versions of the tools available to burglars today.
- Europa Grade I T2, II T2 & III T2 are certified NT Fire 017 – 60 Paper for one-hour protection of paper from fire by RISE (Research Institutes of Sweden).
- A choice of locking options are available at additional costs.
- Each safe can be equipped with high quality fittings to maximize storage requirements
- Base fixing is standard on all models.
- Light grey finish (RAL 9002).

PRODUCT SPECIFICATIONS

Model	Available T2 Grades	External Height (mm)	External Width (mm)	External Depth (mm)	Depth incl. Handle & Hinge (mm)	Internal Height (mm)	Internal Width (mm)	Internal Depth (mm)	Depth with Door at 90° Open (mm)	Width with Door Fully Open (mm)	Capacity (litres)	Net Weight (kg) T2 Grade I/II/III
M-30	I	568	508	450	507	400	340	209	904	900	28	279/-/-
M-60	I,II	628	528	603	660	460	360	360	1077	941	60	375/381/-
M-115	I,II,III	718	668	663	720	550	500	420	1277	1232	116	534/536/545
M-180	I,II,III	1018	668	663	720	850	500	420	1277	1232	179	676/705/724
M-275	I,II,III	1208	668	773	830	1040	500	530	1387	1232	276	906/880/931
M-345	I,II,III	1468	668	773	830	1300	500	530	1387	1232	345	1030/1060/1097
M-505	I,II,III	1796	903	663	720	1628	735	420	1512	1691	503	1320/1370/1418
M-635	I,II,III	1796	903	773	830	1628	735	530	1622	1691	634	1480/1571/1638

External dimensions exclude handle and hinge projections. In line with certification, weights can vary by +/- 5%.



MODEL SHOWN: VEGA M-40

VEGA

BURGLARY-RESISTANT PROTECTION



KEY FEATURES

- Capable of being installed in confined spaces.
- EN 1143-1 Grade V certified by ECB•S for universal acceptance.
- Designed to be anchored to the floor or rear wall. Anchor points are provided along with an appropriate and approved anchor bolt.
- Sized to fit into confined spaces such as wardrobes, under counters and within furniture.
- Two high security locks fitted which can be customised to suit client's needs.
- Weigh less than 300Kg
- Reduced door furniture profile to give greater installation possibilities.
- Door can be removed by trained installers to make installation easier in difficult to access locations.
- Secured by 32mm diameter strong steel bolts with three operating horizontally, one each vertically top and bottom and a full height engagement bar on the hinge side.

PRODUCT SPECIFICATIONS

Model	External Height (mm)	External Width (mm)	External Depth (mm)	Width With Door Open 180° (mm)	Depth With Door Open 90° (mm)	Internal Height (mm)	Internal Width (mm)	Internal Depth (mm)	Capacity (litres)	Net Weight (kg)	No. of Shelves
M 40	485	525	498	968	986	355	395	278	39	296	1

Door furniture projects 55mm beyond the body depth. In line with certification, weights can vary by +/- 5%.



MODEL SHOWN: EUROPA M-180

EUROPA GVI

BURGLARY-RESISTANT PROTECTION IN GRADE VI



KEY FEATURES

- Professional high security safe protecting valuables, certified by ECB•S in accordance with the stringent European standard.
- A choice of locking options are available at additional costs.
- Each safe can be equipped with high quality fittings to maximize storage requirements.
- Base fixing is standard on all models.
- Light grey finish (RAL 9002).

PRODUCT SPECIFICATIONS

Model	External Height (mm)	External Width (mm)	External Depth (mm)	Depth incl. Handle & Hinge (mm)	Internal Height (mm)	Internal Width (mm)	Internal Depth (mm)	Depth with Door at 90° Open (mm)	Width with Door Fully Open (mm)	Capacity (L)	Net Weight (kg)
M-180	1038	688	663	720	850	500	423	1285	1235	180	1012
M-275	1228	688	773	830	1040	500	533	1395	1235	277	1296
M-345	1488	688	773	830	1300	500	533	1395	1695	347	1535
M-505	1816	923	663	720	1628	735	423	1520	1695	506	2089
M-640	1816	923	773	830	1628	735	533	1630	1695	638	2271

External dimensions exclude handle and hinge projections. In line with certification, weights can vary by +/- 5%.

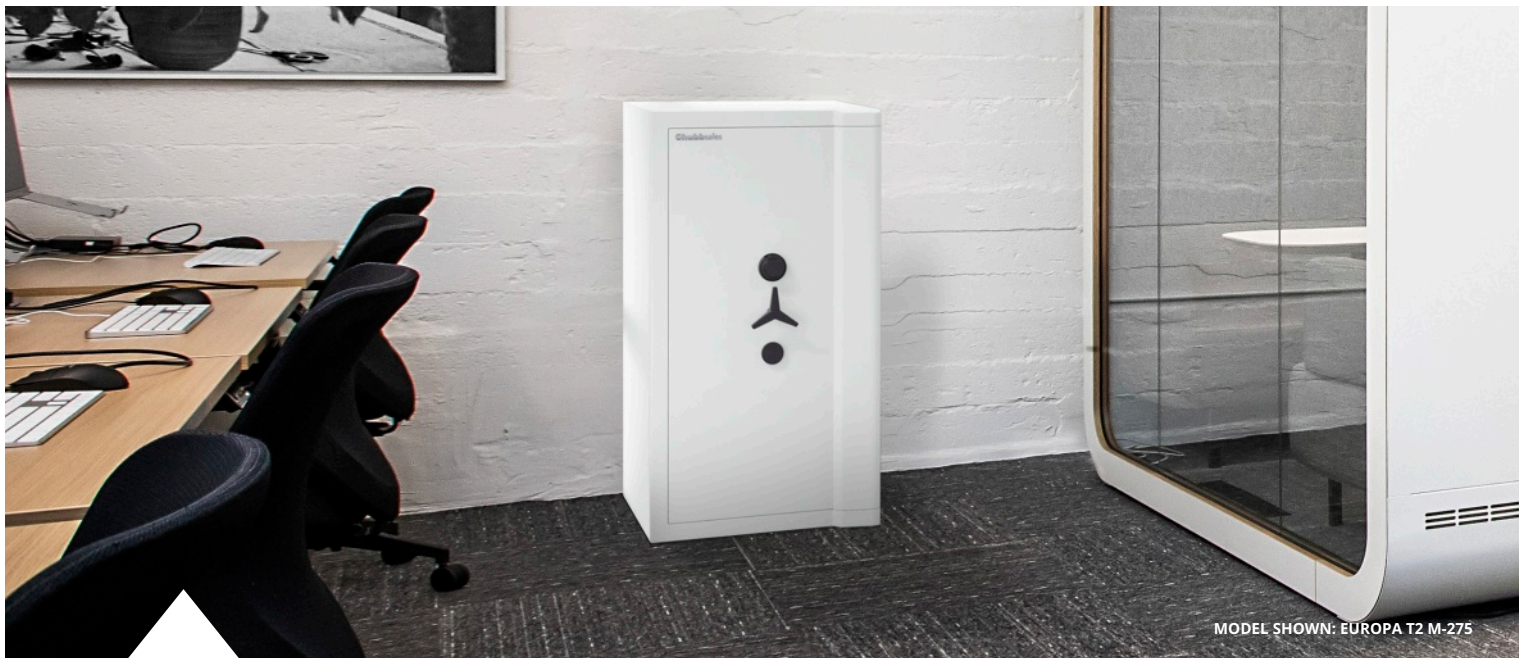

MODEL SHOWN: EUROPA T2 M-275

EUROPA GV T2

BURGLARY-RESISTANT PROTECTION IN GRADE V T2

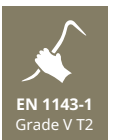

KEY FEATURES

- Professional high security safe protecting valuables up to the highest certified resistance levels, available in Grade V T2, certified by ECB•S in accordance with the stringent European standard, EN 1143-1 T2. Europa hereby complies and is certified with the world's strictest requirements for quality and burglary resistance.
- EN 1143-1:2019 is the latest version of this globally respected burglary resistant standard. The new T2 classification includes tests with the more powerful and effective versions of the tools available to burglars today.
- A choice of locking options are available at additional costs.
- Each safe can be equipped with high quality fittings to maximize storage requirements.
- Base fixing is standard on all models.
- Light grey finish (RAL 9002).

PRODUCT SPECIFICATIONS

Model	External Height (mm)	External Width (mm)	External Depth (mm)	Depth incl. Handle & Hinge (mm)	Internal Height (mm)	Internal Width (mm)	Internal Depth (mm)	Depth with Door at 90° Open (mm)	Width with Door Fully Open (mm)	Capacity (L)	Net Weight (kg)
M-140	718	668	663	720	588	538	444	1277	1232	141	583
M-210	1018	668	663	720	888	538	444	1277	1232	212	773
M-320	1208	668	773	830	1078	538	554	1387	1232	321	983
M-400	1468	668	773	830	1338	538	554	1387	1232	399	1153
M-570	1796	903	663	720	1666	773	444	1512	1691	572	1523
M-715	1796	903	773	830	1666	773	554	1622	1691	714	1683

External dimensions exclude handle and hinge projections. In line with certification, weights can vary by +/- 5%.



DUOFORCE T2

BURGLARY & FIRE-RESISTANT PROTECTION



KEY FEATURES

- Burglary resistance in accordance with the updated and more stringent European standard, EN 1143-1:2019 T2, as certified by ECB•S for Grade IV T2 to VI T2.
- Meets the demands of all insurance companies when it comes to burglary resistance.
- Tested by an independent, ISO 17025 accredited laboratory according to the NT Fire 017 – 60 Paper standard with certification managed by ECB•S. Protects your vital documents from the effects of fire.
- Optional Planar Protection is a fully integrated, alarm wiring matrix within the safe body.
- Optional Core Drill (CD) resistance in accordance with the stringent European standard EN 1143-1:2019 T2, certified by ECB•S for Grade IV T2 CD to VI T2 CD. This is an industry first, whilst at the same time retaining fire protection.
- Supplied with two locks as standard with the option of a factory-fitted electronic lock. This gives the flexibility to customise how DuoForce T2 can be secured and operated
- Ergonomic soft-touch handle and a range of internal fittings to maximise storage capacity

Model	External Height (mm) Gr. IV,V/VI	External Width (mm) Gr. IV,V/VI	External Depth (mm) Gr. IV,V/VI	Internal Height (mm) Gr. IV,V/VI	Internal Width (mm) Gr. IV,V/VI	Internal Depth (mm) Gr. IV,V/VI	Capacity (litres) Gr. IV,V/VI	Net Weight (kg) Gr. IV/V/VI	Net Weight with CD (kg) Gr. IV/V/VI	No. of Shelves
M-65	739/-	574/-	584/-	555/-	390/-	303/-	65/-	541/577/-	562/596/-	1
M-95	974/994	574/594	584/604	790	390	303	95	679/727/801	706/752/825	2
M-245	974/994	824/844	764/784	790	640	483	245	1058/1137/1268	1103/1181/1312	2
M-405	1494/1514	824/844	764/784	1310	640	483	405	1444/1588/1741	1513/1654/1808	3
M-520	1874/1894	824/844	764/787	1690	640	483	520	1816/1993/2187	1904/2070/2264	4
M-885	1874/1894	1274/1294	764/784	1690	1090	483	885	2517/2766/3033	2649/2873/3141	4
M-1090	1874/1894	1524/1544	764/784	1690	1340	483	1090	2889/3180/3488	3041/3309/3617	4

SPECIFICATIONS FOR **OPTIONAL FITTINGS** ARE AVAILABLE ON PAGE 45

CD=Core Drill. External dimensions exclude handle and hinge projections. In line with certification, weights can vary by +/- 5%.



MODEL SHOWN: TRIFORCE T2 M-405

TRIFORCE T2

BURGLARY, FIRE & EXPLOSION-RESISTANT PROTECTION



KEY FEATURES

- Burglary resistance in accordance with the updated and more stringent European standard, EN 1143-1:2019 T2, as certified by ECB•S for Grade IV T2 to VI T2.
- Tested by an independent, ISO 17025 accredited laboratory according to the NT Fire 017 – 60 Paper standard with certification managed by ECB•S. Protects your vital documents from the affects of fire.
- Protection against explosives in Grade IV T2 EX to VI T2 EX. Certified by ECB•S in accordance with the stringent European standard, EN 1143-1:2019.
- Optional Core Drill (CD) resistance in accordance with the stringent European standard EN 1143-1:2019 T2, certified by ECB•S for Grade IV T2 CD to VI T2 CD. This is an industry first, whilst at the same time retaining fire protection.
- Optional Planar Protection is a fully integrated, alarm wiring matrix within the safe body. Designed to be connected up to existing in-situ security systems.
- Supplied with two locks as standard with the option of a factory fitted electronic lock.
- Ergonomic soft-touch handle and a range of internal fittings to maximise storage capacity.

PRODUCT SPECIFICATIONS

Model	External Height (mm) Gr. IV,V/VI	External Width (mm) Gr. IV,V/VI	External Depth (mm) Gr. IV,V/VI	Internal Height (mm)	Internal Width (mm)	Internal Depth (mm)	Capacity (litres)	Net Weight (kg) Gr. IV/V/VI	Net Weight with CD (kg) Gr. IV/V/VI	No. of Shelves
M-95	974/994	574/594	584/604	790	390	303	95	702/751/824	729/776/849	2
M-245	974/994	824/844	764/784	790	640	483	245	1084/1175/1283	1128/1219/1327	2
M-405	1494/1514	824/844	764/784	1310	640	483	405	1525/1662/1834	1594/1728/1900	3
M-520	1874/1894	824/844	764/787	1690	640	483	520	1849/2025/2201	1937/2103/2279	4
M-885	1874/1894	1274/1294	764/784	1690	1090	483	885	2648/2885/3164	2780/2993/3272	4
M-1090	1874/1894	1524/1544	764/784	1690	1340	483	1090	3026/3316/3625	3178/3445/3754	4

SPECIFICATIONS FOR **OPTIONAL FITTINGS** ARE AVAILABLE ON PAGE 45

CD=Core Drill. External dimensions exclude handle and hinge projections. In line with certification, weights can vary by +/- 5%.



MODEL SHOWN: SIGMA DEPOSIT M-30

SIGMA DEPOSIT

BURGLARY-RESISTANT PROTECTION



KEY FEATURES

- Protects organisations from opportunist attacks.
- Ideal for receiving small deposits of cash during business and non-business hours without the need to open the main door.
- Securely holds cash without the need for the safes to be opened.
- Ensures that large quantities of money do not accumulate in the cash till.
- Laser-cut door made of 8 mm plate steel.
- Body made from 3 mm steel.
- 25mm diameter steel locking bolts.
- Shelf supplied in model 50.
- Sigma Free Standing Deposit Safes come with two lock options:
 - Double-bitted 8-lever key lock.
 - A programmable electronic lock (available for M-40 and M-50).
- An anchoring kit is supplied so the safe can be securely base- or rear-fixed, preventing unauthorised removal once installed.

PRODUCT SPECIFICATIONS

Model	External Height (mm)	External Width (mm)	External Depth (mm)	Internal Height (mm)	Internal Width (mm)	Internal Depth (mm)	Capacity (litres)	Net Weight (kg)
M-30	305	375	350	299	369	289	32	27
M-40	375	375	350	369	369	289	39	33
M-50	475	375	350	469	369	289	50	38

External dimensions exclude handle and hinge projections. Weights can vary by +/- 5%. Deposit Slot measures 170mm wide x 16mm high.



MODEL SHOWN: OMEGA DEPOSIT M-50

OMEGA DEPOSIT

BURGLARY-RESISTANT PROTECTION



KEY FEATURES

- Protects organisations from opportunist attacks.
- Ideal for retail outlets operating remotely from central areas and in multi-shift or out-of-hours environments where key holders are not always available.
- Securely holds cash without the need for the safes to be opened.
- Ensures that large quantities of money do not accumulate in the cash till.
- Door is made from 10mm steel.
- Body is made from 6mm steel.
- 20mm diameter steel bolts secure the door.
- Door bolts operate in three directions.
- An anti-fishing device prevents deposits from being removed once deposited into the deposit chute.
- Shelf supplied with model 50.
- Omega Deposit comes with three lock options:
 - Double-bitted 8-lever key lock.
 - A programmable multi-user electronic lock with optional dual control.
 - Electronic lock complete with a double bitted, emergency override key.
- An anchoring kit is supplied so the safe can be securely base- or rear-fixed, preventing unauthorised removal once installed.

PRODUCT SPECIFICATIONS

Model	External Height (mm)	External Width (mm)	External Depth (mm)	Internal Height (mm)	Internal Width (mm)	Internal Depth (mm)	Capacity (litres)	Net Weight (kg)
M-25	455	340	380	212	328	308	24	54
M-50	698	340	380	455	328	308	48	75

External dimensions exclude handle and hinge projections. Weights can vary by +/- 5%. Deposit opening measures 80mm high x 265mm wide x 220mm deep.



RHINO MK II DT



BURGLARY & FIRE-RESISTANT PROTECTION

KEY FEATURES

- Designed for retail and commercial use.
- 65mm barrier thickness made of a high-density monolithic casting contained within inner and outer steel casings.
- Solid composite 35mm thick main door is combined with additional protection plates to protect crucial locking areas. Solid steel 28.5 mm diameter moving bolts attach the door to the body, while fixed "anti-heeling" bolts on the door's rear edge protect the hinge side.
- Deposit drawer with solid 10mm steel plate front combined with an internal anti-fishing mechanism to secure all items deposited.
- Main door secured by EN 1300 Class A primary locks which can be single lock, be it a key lock, manual combination or electronic lock depending upon individual requirements. For additional security, a second lock is possible.
- Drawer deposit unit secured by a single EN 1300-certified Class A lock.
- Two security fixing bolts to ensure it can be firmly fixed to the floor when installed.

PRODUCT SPECIFICATIONS

Model	External Height (mm)	External Width (mm)	External Depth (mm)	Internal Height (mm)	Internal Width (mm)	Internal Depth (mm)	Capacity (litres)	Net Weight (kg)
M-40	654	500	501	270	370	320	40	256
M-55	854	500	501	470	370	320	56	330
M-75	1004	500	501	620	370	320	73	353
M-130	1004	630	601	620	500	420	130	453
M-180	1234	630	601	850	500	420	179	533

External dimensions exclude handle and hinge projections. Weights can vary by +/- 5%.



MODEL SHOWN: EUROPA DEPOSIT M-180

EUROPA DEPOSIT

BURGLARY-RESISTANT PROTECTION



KEY FEATURES

- High quality deposit safe constructed from modern high specification materials.
- Deposit feature allows multiple users to constantly deposit cash and valuables securely whilst the main body of the safe remains locked.
- Can be customised with various locking options to suit your requirements.
- Optional internal fittings available: retaining shelf and retaining cupboard.
- Deposit drawer is secured by a double bitting key lock.

PRODUCT SPECIFICATIONS

Model	External Height (mm)	External Width (mm)	External Depth* (mm)	Internal Height (mm)	Internal Width (mm)	Internal Depth (mm)	Volume** (litres)	Weight (kg)	No. of Standard Key Locks
M-60, GI	882	528	603	460	360	360	60	525	1
M-115, GI	972	668	663	550	500	420	116	694	1
M-180, GI	1272	668	663	850	500	420	180	852	1
M-115, GIII	972	668	663	550	500	420	116	754	2
M-180, GIII	1272	668	663	850	500	420	180	918	2
M-140, GV	972	668	663	588	538	444	140	798	2
M-210, GV	1272	668	663	888	538	444	212	1052	2

SPECIFICATIONS FOR **OPTIONAL FITTINGS** ARE AVAILABLE ON PAGE 45

*Projection of handle (56mm) not included. **Internal volume does not include allowance for anti-fishing devices. External dimensions exclude handle and hinge projections. Weights can vary by +/- 5%.



MODEL SHOWN: PROGUARD DT M-45

PROGUARD DT

BURGLARY-RESISTANT PROTECTION



KEY FEATURES

- Certified, tested and approved in accordance with the European EN 1143-2 standard, in Grades DI and DII.
- EN 1143-2 certified meaning that insurance ratings are not affected by the additional deposit function.
- Constructed using a new composite material designed for strength and reduction in total weight, keeping transportation and installation costs to a minimum.
- Solid steel three-way boltwork.
- Anti-fishing device to prevent anyone reaching the contents through the drawer.
- Fitted with an active relocker and anti-drilling plates incorporated into the boltwork to resist burglary attempts.
- A Class A mechanical key lock or a Class B electronic lock, approved in accordance with EN 1300, available as primary lock options. Electronic locks increase the level of security and prevent unauthorised access.
- Drawer trap fitted with a Class A key lock as standard but alternatives are available upon request.

PRODUCT SPECIFICATIONS

Model	External Height (mm)	External Width (mm)	External Depth (mm)	Internal Height (mm)	Internal Width (mm)	Internal Depth (mm)	Net Weight (kg) Gr I	Net Weight (kg) Gr II	Capacity * (litres)	Drawer Width (mm)	Drawer Depth (mm)
M-45	687	500	521	314	400	360	162	302	45	350	230
M-90	847	600	561	474	500	386	218	426	91	450	230
M-125	1052	600	561	659	500	386	242	499	127	450	230
M-180	1307	600	561	934	500	386	290	602	180	450	230

External dimensions exclude handle and hinge projections. Weights can vary by +/- 5%. * Useable volume below deposit and anti-fishing device.



MODEL SHOWN: EXECUTIVE M-40

EXECUTIVE

FIRE-RESISTANT DOCUMENT PROTECTION

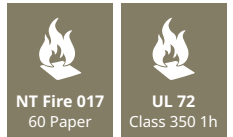

KEY FEATURES

- Fire can strike anywhere – the office or the home. Executive Cabinets provide peace of mind: in the event of a fire breaking out, you can be sure that your paper work can be recovered in a usable condition.
- Ideal for storing essential documents such as wills, property deeds, contracts, insurance policies and many more.
- Certified by both RISE (NT Fire 017 – 60 Paper) and UL (UL Class 350 1hr) for 60 minutes' fire resistance.
- Overall body thickness of 50mm, comprising an inner and outer steel body containing a specially formulated fire-resistant solid barrier material.
- Models come with a choice of two lock options – A cylinder lock utilising a secure flat profile key.
- Programmable and user-friendly electronic lock.
- Overall door thickness of 66mm.
- An anchoring kit is supplied which allows the safe to be securely base-fixed, preventing unauthorised removal.
- Comes with internal fittings as standard, meaning that the unit is ready for use as soon as it is received.

PRODUCT SPECIFICATIONS

Model	External Height (mm)	External Width (mm)	External Depth (mm)	Internal Height (mm)	Internal Width (mm)	Internal Depth (mm)	Capacity (litres)	Net Weight (kg)	No. of Trays	No. of Shelves
M-40	525	410	450	415	305	320	41	57	1	1
M-70	670	550	510	515	395	340	71	120	0	2

External dimensions exclude handle and hinge projections. In line with certification, weights can vary by +/- 5%.



MODEL SHOWN: DPC M-400P

DPC

FIRE-RESISTANT DOCUMENT PROTECTION



UL 72
Class 350
2hr

KEY FEATURES

- High capacity storage solution with fire protection, ideal for office environments such as banks and financial institutions.
- Certified by Underwriter's Laboratories according to UL 72 Class 350 for up to 120 minutes fire protection.
- Automatic mechanism to ensure bolts are in place and able to resist fire whenever the door is closed.
- Interlocking door system on double door models to prevent the cabinet from being left open.
- Available in six high-capacity sizes from 160 to 670 litres.
- EN 1300 Class A certified key lock fitted as standard.
- Dual locking or single electronic or manual combination locks available at additional costs.
- Anchoring kit to fix the safe on the floor and prevent from unauthorised removal available on request.
- Shelf/shelves supplied as standard.
- Optional internal fittings available including pull out file frames and lockable drawers and cupboards.
- RAL 7035 body & RAL 7016 facia panel.

PRODUCT SPECIFICATIONS

Model	External Height (mm)	External Width* (mm)	External Depth** (mm)	Internal Height (mm)	Internal Width*** (mm)	Internal Depth (mm)	Capacity (litres)	Net Weight (kg)	No. of Shelves	No. of Doors
M-160	859	759	551	700	600	382	160	235	1	1
M-240	1209	759	551	1050	600	382	240	315	2	1
M-400L	1209	1160	551	1050	1000	382	401	500	2	2
M-320	1559	759	551	1400	600	382	321	395	3	1
M-400P	1909	759	551	1750	600	382	401	470	4	1
M-670	1909	1160	551	1750	1000	382	670	650	4	2

SPECIFICATIONS FOR **OPTIONAL FITTINGS** ARE AVAILABLE ON PAGE 45

*Projection of hinge (27mm) not included. **Projection of handle (54mm) not included. ***Width excluding shelf racking strips. Racking reduces the internal width by 10mm



MODEL SHOWN: 6000 SERIES FILES, SIZE 6425

6000 SERIES FILES

FIRE-RESISTANT DOCUMENT PROTECTION



KEY FEATURES

- Cost effective, certified protection for files and documents.
- Certified according to EN 15659 LFS 60 P.
- Designed to take most suspension files.
- Available in two or four drawer versions.
- Easy-to-operate day catch to secure the drawers when closed.
- Units do not have to be locked to provide fire protection but just to be pushed closed.
- Fitted with one key lock controlling all drawers as standard.
- The option of dual locking, combination and key lock is available.
- Additional drawers may be individually locked by a key lock if desired.
- Light Grey RAL 7035, powder-coated finish and modern design which blends nicely into any office environment.
- Manufactured in accordance with ISO 9001 for quality management systems and ISO 14001 for environmental management systems.

PRODUCT SPECIFICATIONS

Model	External Height (mm)	External Width (mm)	External Depth (mm)	Drawer Height (mm)	Drawer Width (mm)	Drawer Depth (mm)	Net Weight (kg)
6225	737	544	634	292	385	476	142
6425	1408	544	634	292	385	476	250
6230	737	544	776	292	385	633	165
6430	1408	544	776	292	385	633	306

External dimensions exclude handle and hinge projections. In line with certification, weights can vary by +/- 5%.



MODEL SHOWN: FIRE FILE 25" M-210

FIRE FILE 25"

FIRE-RESISTANT DOCUMENT PROTECTION



KEY FEATURES

- Certified for one hour's fire protection of documents in accordance with UL Standard 72, Class 350 Endurance.
- Maximised capacity that users can take full advantage of for their storage requirements.
- Chubb Safes' Fire File 25" is available in two- or four-drawer versions.
- Easy-to-operate day catch to secure the drawers when closed.
- Units do not have to be locked to provide fire protection: they just have to be pushed closed.
- High-quality steel sliders to ensure comfortable operation and full drawer access.
- Lighter weight construction which means smoother transportation and installation.
- All models fitted with high-security locks as standard.
- Light Grey RAL 7035, powder-coated finish and modern design which blends nicely into any office environment.
- Chubb Safes' Fire File 25" is manufactured in accordance with ISO 9001 for quality management systems and ISO 14001 for environmental management systems.

PRODUCT SPECIFICATIONS

Model	External Height (mm)	External Width (mm)	External Depth (mm)	Internal Height (mm)	Internal Width (mm)	Internal Depth (mm)	Capacity (litres)	Net Weight (kg)	No. of Drawers
M-105	784	551	635	290	387	460	104	164	2
M-210	1510	551	635	290	387	460	208	291	4

External dimensions exclude handle projections. In line with certification, weights can vary by +/- 5%.



MODEL SHOWN: FIRE FILE 31" M-270

FIRE FILE 31"

FIRE-RESISTANT DOCUMENT PROTECTION



KEY FEATURES

- Certified according with UL standard 72 in Class 350 Endurance for both 1 hour and 2 hour duration.
- Available in two-, three- or four-drawer versions.
- On the two-hour certified models, each drawer is fire-protected. Even if one of the drawers is accidentally left open, the other closed drawers are still protected by the built in fire resistance partitions.
- Easy-to-operate day catch to secure the drawers when closed. Units do not have to be locked to provide fire protection but just to be pushed closed.
- High-quality steel sliders to ensure comfortable operation and full drawer access.
- Lighter weight construction which means smoother transportation and installation.
- Fitted with high-security locks as standard.
- Light Grey RAL 7035, powder-coated finish and modern design.
- Manufactured in accordance with ISO 9001 for quality management systems and ISO 14001 for environmental management systems.

PRODUCT SPECIFICATIONS

Model	External Height (mm)	External Width (mm)	External Depth (mm)	Drawer Height (mm)	Drawer Width (mm)	Drawer Depth (mm)	Capacity (litres)	Net Weight (kg) 1h / 2h	No. of Drawers
M-135	784	551	779	290	387	604	136	194 / 197	2
M-205	1147	551	779	290	387	604	204	268 / 273	3
M-270	1510	551	779	290	387	604	272	321 / 328	4

External dimensions exclude handle projections. In line with certification, weights can vary by +/- 5%.



MODEL SHOWN: LATERAL FIRE FILE M-360

LATERAL FIRE FILE

FIRE-RESISTANT DOCUMENT PROTECTION



KEY FEATURES

- Certified by UL Underwriters Laboratories) to Class 350 Endurance 1 hour in accordance with Standard 72.
- Perfectly designed for today's modern offices, it sits closer to the wall for marginally more filing than traditional large filing cabinets, offering exceptional functionality and optimised storage.
- Maximised storage capacity with 3 or 4 drawers so users can fully meet their storage requirements.
- Easy-to-operate day catch to secure the drawers when closed.
- Units do not have to be locked to provide fire protection: they simply need to be pushed closed.
- High-quality steel sliders to ensure comfortable operation and full drawer access.
- Low-weight for reduced transportation and installation costs, and lighter floor loads.
- All models fitted with high-security locks as standard.
- Light Grey RAL 7035, powder-coated finish and modern design which blends nicely into any office environment.
- Manufactured in accordance with ISO 9001 for quality management systems and ISO 14001 for environmental management systems.

PRODUCT SPECIFICATIONS

Model	External Height (mm)	External Width (mm)	External Depth (mm)	Drawer Height (mm)	Drawer Width (mm)	Drawer Depth (mm)	Capacity (litres)	Net Weight (kg)	No. of Drawers
M-270	1147	964	586	290	800	387	270	328	3
M-360	1510	964	586	290	800	387	359	411	4

External dimensions exclude handleprojections. In line with certification, weights can vary by +/- 5%.



MODEL SHOWN: BINDER FIRE FILE M-160



UL 72
Class 350 2h

BINDER FIRE FILE

FIRE-RESISTANT DOCUMENT PROTECTION

KEY FEATURES

- Certified UL Class 350 Endurance protection by UL for up to two hours.
- Maximised storage capacity that allows users to gain full advantage for their storage requirements. Available with 3 or 4 drawers and each drawer holds up to 40 A4 DIN 33mm binders, hence 120 and 160 binders in the three drawer and four drawer versions respectively. By comparison, a standard free standing cabinet with five levels of storage each of 1m length can only hold 150 such binders. Thus the Chubb safes Binder Fire Files are the perfect storage solution for the congested offices.
- Insulation between drawers means each drawer's contents are protected in an event of fire if one drawer is left open.
- Easy operable day catch to secure the drawers when closed. Units do not have to be locked to provide fire protection but just be pushed closed.
- High-quality steel sliders to ensure comfortable operation and full drawer access.
- Low-weight cabinets for reduced transportation and installation costs, and lighter floor loads.
- All models fitted with high-security locks as standard.

PRODUCT SPECIFICATIONS

Model	External Height (mm)	External Width (mm)	External Depth (mm)	Drawer Height (mm)	Drawer Width (mm)	Drawer Depth (mm)	Net Weight (kg)	Capacity (A4 Binders)	No. of Drawers
M-120	1276	801	836	333	637	660	402	120	3
M-160	1682	801	836	333	637	660	495	160	4

External dimensions exclude handle projections. In line with certification, weights can vary by +/- 5%.



MODEL SHOWN: ULTRA FIRE FILE 31" M-270

ULTRA FIRE FILE 31"

FIRE-RESISTANT DOCUMENT PROTECTION



KEY FEATURES

- Certified in accordance with UL Standard 72 in Class 350 Endurance and Impact for both 1-hour and 2-hour durations, providing ultimate peace of mind for mission-critical paper records.
- A shock absorbing plinth provides maximum impact absorption in the event of a floor collapse in a building fire.
- In two-hour certified models, each drawer is individually protected from fire. Even if one of the drawers is accidentally left open, the other closed drawers are still protected.
- Maximised capacity for optimized storage.
- Extended drawers give full access.
- It is available in two-, three- or four-drawer versions.
- Easy-to-operate day catch to secure the drawers when closed.
- Units do not have to be locked to provide fire protection but just to be pushed closed.
- Lighter weight construction, means easier transportation and installation.
- Fitted with high-security locks as standard.
- Light Grey RAL 7035, powder-coated finish and modern design which blends nicely into any office environment.
- Manufactured in accordance with ISO 9001 for quality management systems and ISO 14001 for environmental management systems.

PRODUCT SPECIFICATIONS

Model	External Height (mm)	External Width (mm)	External Depth (mm)	Drawer Height (mm)	Drawer Width (mm)	Drawer Depth (mm)	Capacity (liters)	Net Weight (kg) 1h / 2h	No. of Drawers
M-135	869	551	779	290	387	604	136	201 / 204	2
M-205	1222	551	779	290	387	604	204	275 / 280	3
M-270	1585	551	779	290	387	604	272	328 / 335	4

External dimensions exclude handle projections. In line with certification, weights can vary by +/- 5%.



MODEL SHOWN: DATAGUARD NT M-130

DATAGUARD NT

FIRE-RESISTANT DATA MEDIA PROTECTION



KEY FEATURES

- Certified NT Fire 017 – 120 Diskette for two-hour protection of data media from fire.
- Single-door safe with no insert required – maximising internal capacity and up to 60% more storage space than other safes in the same class.
- User-friendly, slam-action door. When shut, provides full fire protection without needing to be locked.
- Adjustable shelving and drawer units supplied as standard.
- Available in four models, ranging from 30 to 128 litres.
- Choice of key or electronic locking.

PRODUCT SPECIFICATIONS

Model	External Height (mm)	External Width (mm)	External Depth (mm)	Internal Height (mm)	Internal Width (mm)	Internal Depth (mm)	Volume (litres)	Net Weight (kg)	Number of shelves	Number of drawers
M-30	530	546	566	280	346	306	30	145	1	0
M-50	700	546	566	450	346	306	48	190	1	1
M-90	1025	546	590	775	346	330	89	263	1	2
M-130	1025	702	590	775	502	330	128	330	1	2

SPECIFICATIONS FOR **OPTIONAL FITTINGS** ARE AVAILABLE ON PAGE 45

External heights and depths include plinth and handle projection. Internal heights and widths are also equal to the clear opening measurements.



AIR HOTEL

BURGLARY PROTECTION FOR YOUR VALUABLES

KEY FEATURES

- Compact safe for hotel rooms, student accommodation or other locations with frequent occupancy turnover.
- Steel door and body with dual, plated steel moving boltwork.
- User-friendly electronic lock.
- Authorised control and access via electronic lock or optional hand-held programming unit.

PRODUCT SPECIFICATIONS

Model	External Height (mm)	External Width (mm)	External Depth* (mm)	Internal Height (mm)	Internal Width (mm)	Internal Depth (mm)	Capacity (litres)	Net Weight (kg)
M-25	200	430	350	190	420	300	24	12

*Lock projection (10mm) not included.



MODEL SHOWN: AIR M-10



AIR

BURGLARY PROTECTION FOR YOUR VALUABLES

KEY FEATURES

- Compact safe for the home, hotel room or office.
- Three models available: 9-, 16- and 24-litres capacities. The largest is designed to accommodate most laptop computers.
- Choice of locking options: available with a double-bitted key lock or an electronic lock with a programmable code.
- Emergency key override facility for the electronic lock should battery power ever fail.
- Patented “anti-bump” technology which affords the electronic lock protection against impact attacks.
- Tamper-evident keypad.
- Ready for base and for rear fixing, supplied with four expansion anchors.
- Inner base carpet.
- Key hooks included on all electronic models.

PRODUCT SPECIFICATIONS

Model	External Height (mm)	External Width (mm)	External Depth* (mm)	Internal Height (mm)	Internal Width (mm)	Internal Depth (mm)	Capacity (litres)	Net Weight (kg)	No. of Shelves
M-10	200	310	200	190	300	150	9	6	0
M-15	250	350	250	240	340	200	16	9	1
M-25	200	430	350	190	420	300	24	11	0

* In electronic models, add 20mm to allow for keypad projection.



MODEL SHOWN: FORTIS M-70



FORTIS

BURGLARY-RESISTANT PROTECTION

KEY FEATURES

- Available in a range of sizes from 35 to 90 litres, suitable for most requirements.
- Designed to be base anchored to resist removal.
- Choice of a traditional key lock or an automatic locking, user friendly electronic lock.
- Magnetic, repositionable and USB rechargeable LED light.
- Chubb safes' three spoke handle provides visual open or locked condition when used with the factory fitted electronic lock option.
- Adjustable shelves using internal racking location holes maximizing internal width.
- Cork backed mat embossed with Chubb safes logo.

PRODUCT SPECIFICATIONS

Model	External Height (mm)	External Width (mm)	External Depth (mm)	Width With Door Open 180° (mm)	Depth With Door Open 90° (mm)	Internal Height (mm)	Internal Width (mm)	Internal Depth (mm)	Capacity (litres)	Net Weight (kg)	No. of Shelves
35	450	445	400	837	815	360	355	291	36	64	1
50	600	445	400	837	815	510	355	291	51	79	1
70	800	445	400	837	815	710	355	291	71	100	2
90	1000	445	400	837	815	910	355	291	91	120	3

Door furniture projects 30mm beyond the body depth. In line with certification, weights can vary by +/- 5%



MODEL SHOWN: HOMESAFE S2 30P M-50

HOMESAFE S2 30P

BURGLARY & FIRE-RESISTANT PROTECTION



KEY FEATURES

- Combined fire and burglary protection in one product.
- EN 14450 certified by ECB•S to level S2 burglary protection.
- EN 15659 certified by ECB•S for 30-minutes' fire protection for documents.
- Choice of 6 models: from 11- to 91-litre capacity.
- Choice of locking options in all models: EN 1300 certified double-bitted key lock or EN 1300 certified electronic lock.
- Dual base fixing holes, supplied with two concrete anchor bolts.
- Ideal solution for protecting cash and valuable items, as well as passports, title deeds and other important documents in the home and office.
- The cabinet's door is secured using the new revolutionary "V" bolt system. The design of the locking bolts helps maintain door integrity both when under physical attack and during a fire.
- The secure cabinet is prepared & anchoring kit is supplied to allow the HomeSafe S2 30P range to be securely base- or rear-fixed to resist unauthorised removal once installed.

PRODUCT SPECIFICATIONS

Model	External Height (mm)	External Width (mm)	External Depth (mm)	Internal Height (mm)	Internal Width (mm)	Internal Depth (mm)	Capacity (litres)	Net Weight (kg)	No. of Shelves
M-10	300	360	300	210	270	191	11	24	1
M-20	300	445	390	210	355	281	21	32	1
M-35	450	445	390	360	355	281	36	42	1
M-50	600	445	390	510	355	281	51	53	1
M-70	800	445	390	710	355	281	71	65	2
M-90	1000	445	390	910	355	281	91	78	2

Hinges project 20mm beyond the depth given above. In standard electronic models, the overall projection increases to 30mm.



RHINO MK II

BURGLARY & FIRE-RESISTANT PROTECTION



KEY FEATURES

- Body barrier thickness of 65mm; constructed from steel, welded throughout and filled with specially formulated Chubb safes barrier material.
- A solid composite 35mm thick door is combined with additional protection plates for crucial locking areas.
- Solid steel moving bolts with a 28.5mm diameter affix the door to the body, while fixed “anti-heeling” bolts on both front and rear edges protect the door from prying attack.
- A Polyurethane base paint finish is used to coat the body and door. The paint is both scratch resistant and durable.
- Tested in accordance with EN 14450 Level S2, certified by ECB•S.
- Rhino Mk II has been tested in accordance with EN 15659, and is certified to level LFS 60 P by ECB•S giving 1 hour fire protection.

PRODUCT SPECIFICATIONS

Model	External Height (mm)	External Width (mm)	External Depth* (mm)	Internal Height (mm)	Internal Width (mm)	Internal Depth (mm)	Volume (litres)	Net Weight** (kg)
M-30	400	500	502	270	370	325	32	158
M-55	600	500	502	470	370	325	57	213
M-75	750	500	502	620	370	325	75	255
M-130	750	630	602	620	500	425	132	341
M-180	980	630	602	850	500	425	181	421

SPECIFICATIONS FOR **OPTIONAL FITTINGS** ARE AVAILABLE ON PAGE 45

* Handle projection is 56mm. ** In line with certification, weights can vary by +/- 5%



MODEL SHOWN: MINI BANKER MK II, SIZE 4

MINI BANKER MK II

BURGLARY & FIRE-RESISTANT PROTECTION



KEY FEATURES

- Body barrier thickness of 65mm; constructed from steel, welded throughout and filled with specially formulated Chubb Safes barrier material.
- A solid composite 35mm thick door is combined with additional protection plates for crucial locking areas.
- Solid steel moving bolts with a 28.5mm diameter affix the door to the body, while fixed “anti-heeling” bolts on both front and rear edges protect the door from prying attack.
- Glass relocker to ensure bolts to remain firmly in place should an attack on the lock occur (featured on model 2 and above).
- A Polyurethane base paint finish is used to coat the body and door. The paint is both scratch resistant and durable
- Tested in accordance with EN 14450 Level S2, certified by ECB•S.
- Fire Resistance tested in accordance to the Japanese Industrial Standard JIS S 1037 with fire resistance for up to 60 minutes.

PRODUCT SPECIFICATIONS

Model	External Height (mm)	External Width (mm)	External Depth* (mm)	Internal Height (mm)	Internal Width (mm)	Internal Depth (mm)	Capacity (litres)	Net Weight** (kg)	No. of Shelves	No. of Drawers
1	410	360	386	280	230	205	13	104	1	0
2	488	435	461	358	305	280	31	157	1	1
3	590	435	461	460	305	280	39	180	1	1
4	590	550	576	460	420	395	76	257	1	1
5	717	550	576	587	420	395	97	293	1	1
6	894	550	576	764	420	395	127	347	1	1
7	1047	640	666	917	510	485	227	481	1	1

* Handle projection is 56mm. ** In line with certification, weights can vary by +/- 5%



MODEL SHOWN: ARCHIVE CABINET M-450

ARCHIVE CABINET



FIRE-RESISTANT DOCUMENT PROTECTION

KEY FEATURES

- Archive Cabinet has a steel, double-wall construction insulated with special fire-resistant barrier material.
- Available in four models with a generous storage capacity ranging from 325 to 880 litres.
- Secured by three-way boltwork, locking at the top, bottom and side of the door.
- EN 1300 Class A certified key lock fitted as standard.
- A wide range of flexible fittings available to suit all types of storage requirements, including removable shelves, extendable file frames for A4 or Folio files and a lockable compartment.
- Anchor points in the base allow the cabinet to be fixed to the floor.
- All cabinets have a light-grey, powder-coated finish, suitable for any office space.

PRODUCT SPECIFICATIONS

Model	External Height (mm)	External Width (mm)	External Depth* (mm)	Internal Height (mm)	Internal Width (mm)	Internal Depth (mm)	Capacity (litres)	Net Weight (kg)	No. Of Shelves
M-325	1500	700	550	1290	594	430	325	95	3
M-450	1950	700	550	1780	594	430	450	120	4
M-640	1950	950	550	1780	844	430	640	150	4
M-880	1950	1260	550	1780	1154	430	880	200	4

SPECIFICATIONS FOR **OPTIONAL FITTINGS** ARE AVAILABLE ON PAGE 45

*Projection of handle (50mm) not included.



MODEL SHOWN: FORCEGUARD M-920

FORCEGUARD

BURGLARY-RESISTANT PROTECTION



KEY FEATURES

- Available in four models, from 218 to 815 litres, with double doors on models M-610–M-815.
- Single-wall body and door made from 3mm solid steel. Doors have a total thickness of 52mm and open to 180°.
- Secured by three-way boltwork, locking at the top, bottom and side of the door. All bolts are chrome-plated and 20mm in diameter.
- Doors also fitted with relocking device for additional protection against attempted forced entry.
- Key lock (Class A), combination lock (class B) or electronic lock (class B) fitted as standard. All locks approved in accordance with the European EN 1300 standard.
- All models equipped with removable shelves designed to accommodate hanging files.
- Anchor points in the base allow the cabinet to be fixed to the floor.
- All cabinets have a light-grey, powder-coated finish, suitable for any office space (RAL 7035).

PRODUCT SPECIFICATIONS

Model	External Height (mm)	External Width (mm)	External Depth* (mm)	Internal Height (mm)	Internal Width (mm)	Internal Depth (mm)	Capacity (litres)	Net Weight (kg)	No. of Doors	No. of Shelves	Rows of Hanging Files	Capacity Hanging Files
M-220	1000	600	450	935	594	400	218	80	1	2	3	1.74
M-505	1500	900	450	1435	894	400	504	140	2	3	4	3.5
M-610	1800	900	450	1735	894	400	610	195	2	4	5	4.37
M-815	1800	1200	450	1735	1194	400	815	240	2	4	5	5.87

*Projection of handle (50mm) not included

OPTIONAL FITTINGS

ARCHIVE CABINET

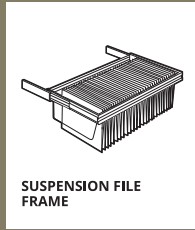

DATAGUARD NT

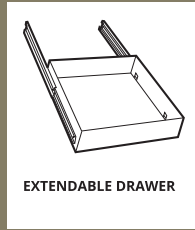

DPC

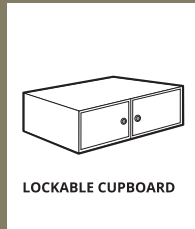
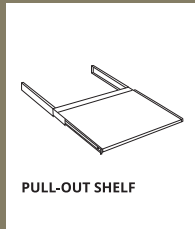
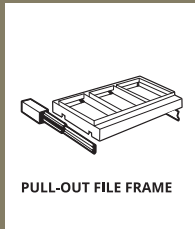

DUOFORCE T2 / TRIFORCE T2



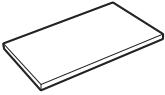
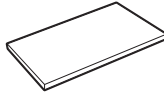
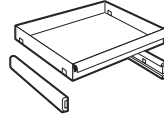
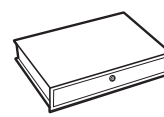
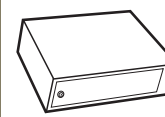

DUOGUARD

 <p>SHELF Max capacity 60kg</p>	 <p>HEAVY DUTY SHELF Max capacity 120kg</p>	 <p>EXTENDABLE SHELF</p>	 <p>EXTENDABLE DRAWER</p>	 <p>LOCKABLE COMPARTMENT</p>
---	---	--	---	--

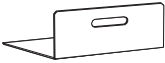
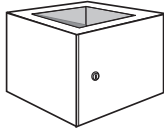
EUROPA DEPOSIT

 <p>RETAINING SHELF</p>	 <p>RETAINING CUPBOARD</p>
---	--

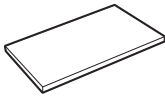
RHINO MK II

 <p>REMOVABLE SHELF</p>	 <p>EXTENDABLE DRAWER</p>
---	--

PROGUARD

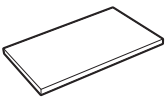
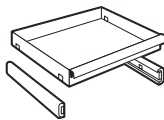
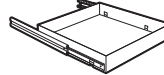
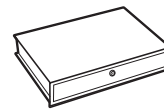
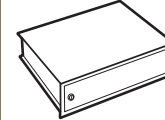
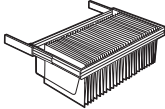
 <p>REMOVABLE SHELF* M-65: 20x375x350 M-120-M-305: 20x475x376 M-365: 20x710x542 M-370: 20x550x400 M-465: 20x550x430</p>	 <p>EXTENDABLE SHELF M-120-M-305: 37x455x376 M-370: 37x530x400 M-465: 20x550x430</p>	 <p>EXTENSIBLE TRAY M-120-M-305: 37x460x361 M-370: 37x535x385 M-465: 37x535x415</p>	 <p>LOCKABLE DRAWER M-120-M-305: 100x460x336 M-370: 100x535x360 M-465: 100x535x390</p>	 <p>LOCKABLE COMPARTMENT M-120-M-305: 335x467x358 M-370: 335x562x382 M-465: 335x562x412</p>	 <p>EXTENSIBLE FILE FRAME M-120-M-305: 37x460x376 M-370-M-465: 37x535x376</p>
---	--	---	--	---	---

www.chubbsafes.com

Authorised dealer

